

TA200TP Turboprop Engine

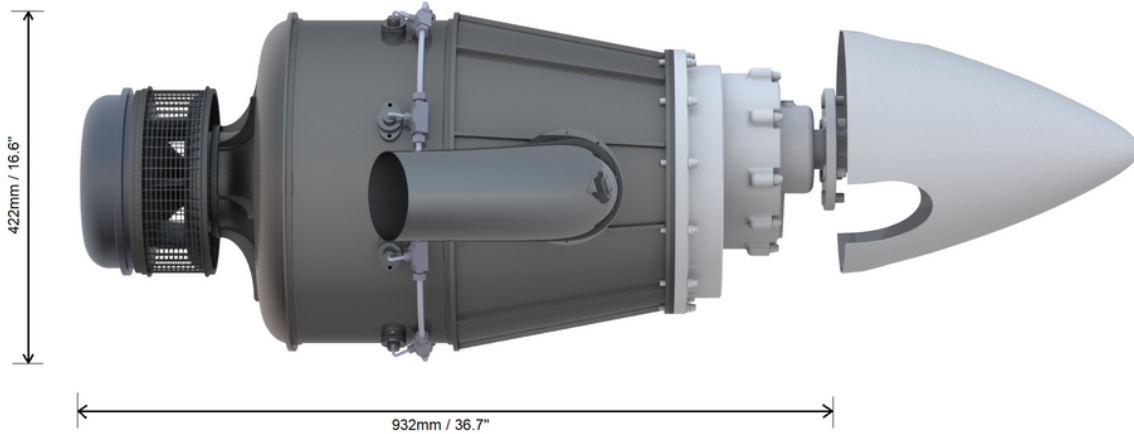

TA200TP	Specifications
Take Off Power	200 hp
Maximum Continuous Power (MCP)	190 hp
Optimum Cruise Power (OCP) @ 10,000', ISA	180 hp
Specific Fuel Consumption	0.56 lbs/hp/hr
Fuel flow @ 150hp @ 10,000', ISA, JetA	12.6gph / 43 litres p.h.
Installed Weight (incl fluids)	270 lbs
TBO	Target > 3000 hrs
Generator	24v,100A
Single Lever Power Control Unit	Offering single lever engine power and propeller control

All specifications are preliminary and are subject to confirmation and change without notice.